

auto electrical parts

Technical Information Sheet

Part No. 0-605-95

Emergency switch for 0-605-35/47 battery isolator, protective clear spring loaded cover and LED indicator. Allows battery isolation to be operated from external point on chassis. Supplied with Schlemmer 4-pin connector for connection to 8.5NW tubing.



Technical Drawing (not to scale)

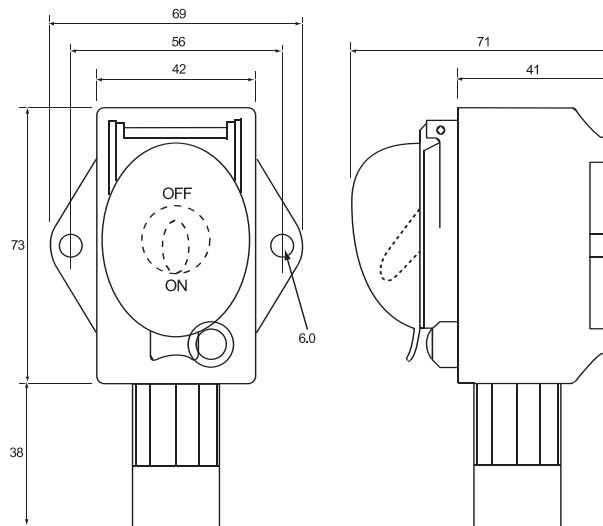

Specification

Type	Battery isolator emergency toggle switch
Application	12/24 volt
Dimensions (sw body)	l 70 x w 72 x h 73mm
Weight	140g

The information contained in this document is correct to the best of our knowledge at the time of printing. However, specifications may change at any time without notice.